

ITEM T81/05

SUBJECT: HEADLAMP LIFT MECHANISM LUBRICATION

MODELS: TR7; TR8

When ANY work involving the headlamp mechanism is to be undertaken, it is ESSENTIAL that a positive check is first made to determine whether the vehicle concerned is within the affected ranges of Recall Campaign A457, detailed in Bulletin 79/Z/4, and if so, that the necessary work has been carried out.

Lubrication of the headlamp lift mechanism should be regarded as a service requirement at C and D service intervals and a good grade of MOLY of P.B.C. grease is recommended.

The pivot bushes on the connecting arm are the key points for lubricant as shown in the illustration but it would also help to apply grease to the main pivot rod to act as a water repellent.

#### WARNING

Before the lubricant is applied, the headlamps should be raised and then rendered in-operative either by isolating the battery or by disconnecting the red multi-plug connectors at either side of the underhood area. This will prevent a headlamp lowering cycle being initiated inadvertently with a consequent risk of injury to the operator.

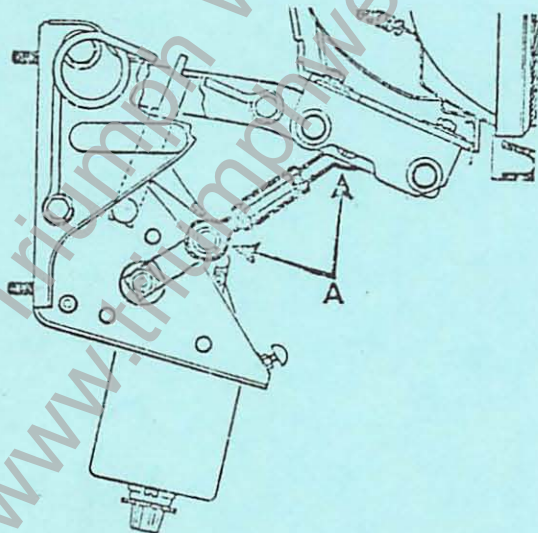

Can

Provided Courtesy Triumph Wedge Owners Association  
<http://www.triumphwedgeowners.org>